



PROGRESSIVE LINK THUMB

INCREASE YOUR RANGE OF MOTION BY UP TO 180°

Transfer hose keeps machine jumper lines shorter & less prone to damage. Available with hard lines if desired.

Built-in storage pin locks the thumb body in place when not in use, preventing hydraulic downdrift.

One piece mounting pad saves hours in installation time and eliminates common lineup issues and mistakes!

Lubricated, replaceable, heat-treated pins and bushings deliver years of dependable performance.

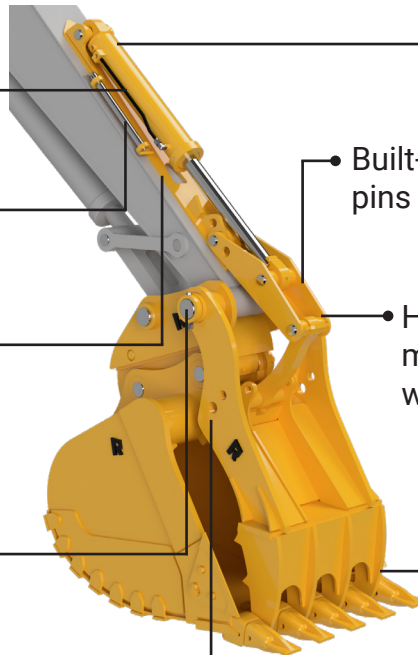

Heavy-duty, dual-cushioned, Rockland manufactured cylinder.

Built-in thumb linkage eliminates modifying link pins and dramatically simplifies installation.

Heavy-duty thumb linkage delivers maximum thumb rotation. Pick and place with great precision!

Thumb tines mesh with bucket teeth. Easily pick-up finer materials.

Curved thumb body profile cradles material. Built-in serrations hold material in place. Rigid box-frame construction withstands the toughest applications.

▶ LOOKING FOR A NON-LINK THUMB?
Check out our Pin Mounted Thumb!

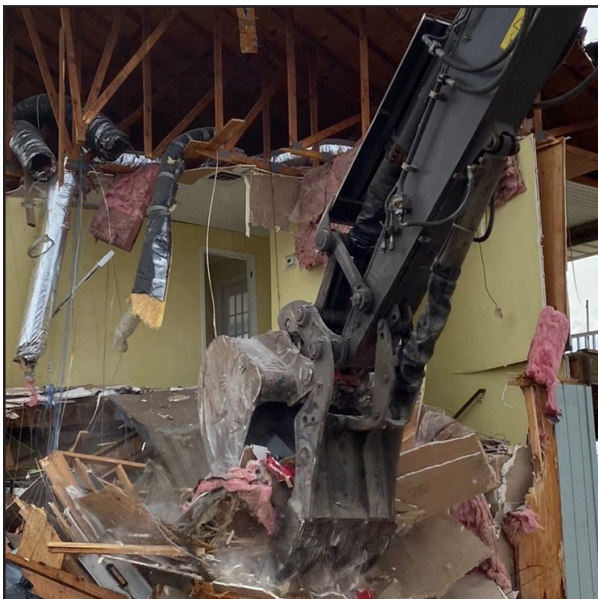

Specifications*

Machine Weight (Lbs.)	Standard Length Weight (Lbs.)	Coupler Length Weight (Lbs.)
15,000 - 25,000	400	455
25,000 - 33,000	845	900
33,000 - 40,000	965	1,065
40,000 - 52,000	1,375	1,455
52,000 - 70,000	1,415	1,610
70,000 - 90,000	1,770	2,155
90,001-110,000	2,050	2,295
110,000 - 160,000	2,525	2,710

Proudly Made in USA

*Specifications subject to change without notice.

WARRANTY Rockland Progressive Link Excavator Thumbs are guaranteed against failure due to defective design, materials, or workmanship for a period of two years or 4,000 hours.

WWW.ROCKLANDMFG.COM | SALES@ROCKLANDMFG.COM | 1-800-458-3773