



# PIN MOUNTED THUMB

INCREASE YOUR RANGE OF MOTION BY UP TO 120°

Transfer hose keeps machine jumper lines shorter & less prone to damage. Available with hard lines if desired.

Built-in storage pin locks the thumb body in place when not in use, preventing hydraulic downdrift.

Lubricated, replaceable, heat-treated pins and bushings deliver years of dependable performance.

Heavy-duty, dual-cushioned, Rockland manufactured cylinder. Thumb follows 65% - 75% of the bucket rotation.

Thumb tines mesh with bucket teeth. Easily pick-up finer materials.

Curved thumb body profile cradles material. Built-in serrations hold material in place. Rigid box-frame construction withstands the toughest applications.

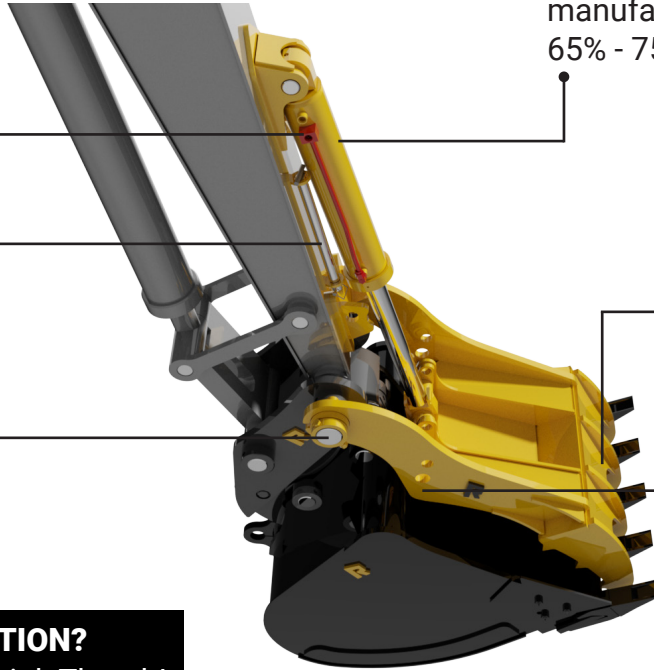

➤ **LOOKING FOR MORE ROTATION?**  
Check out our Progressive Link Thumb!



## Specifications\*

Machine Weight (Lbs.)	Standard Length Weight (Lbs.)	Coupler Length Weight (Lbs.)
15,000 - 25,000	485	515
25,000 - 33,000	1,010	1,080
33,000 - 40,000	1,115	1,220
40,000 - 52,000	1,560	1,725
52,000 - 70,000	1,795	1,835
70,000 - 90,000	2,365	2,480
90,001-110,000	2,900	2,975
110,000 - 160,000	3,350	3,470

Proudly Made in USA

\*Specifications subject to change without notice.

**WARRANTY** Rockland Pin Mounted Excavator Thumbs are guaranteed against failure due to defective design, materials, or workmanship for a period of two years or 4,000 hours.

[WWW.ROCKLANDMFG.COM](http://WWW.ROCKLANDMFG.COM) | [SALES@ROCKLANDMFG.COM](mailto:SALES@ROCKLANDMFG.COM) | 1-800-458-3773