

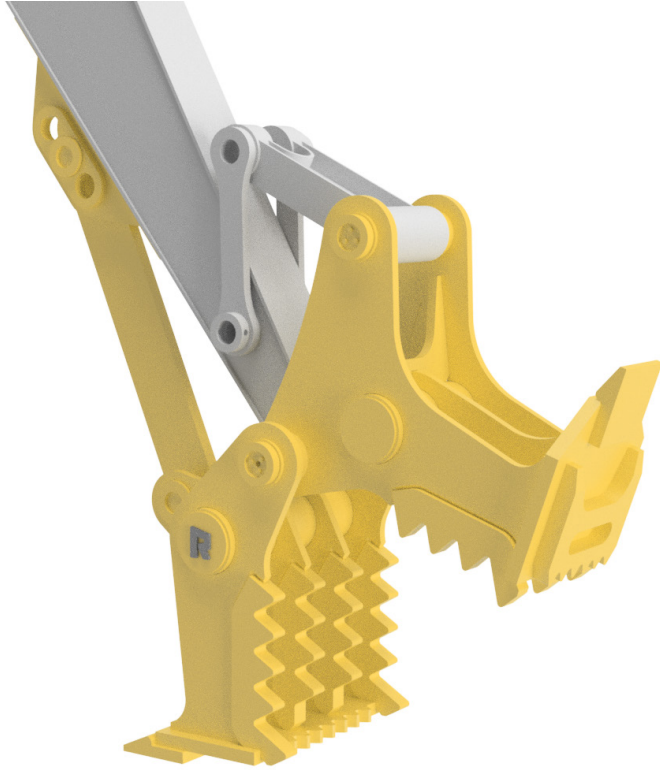

CONCRETE PULVERIZER

Quickly reduce massive concrete slabs and chunks to aggregate!



The Rockland Concrete Pulverizer is a simple, powerful tool that allows demolition contractors to separate concrete and rebar and turn them into recyclable, profitable materials. It installs easily and requires no additional hydraulics, making it an effective alternative to hammers, wrecking balls, and other traditional demolition tools.

The Concrete Pulverizer mounts in place of the excavator bucket and utilizes the excavator's curl cylinder to generate tremendous crushing power. Its open frame design allows crushed material to fall through and prevents impaction.

Crushing jaws are built from abrasion resistant AR400 plate, and pivot on a heavy-duty, heat-treated pivot pin supported by heavy-duty bushings. Its features like these that guarantee years of dependable, trouble free performance in the most demanding crushing applications.

Want to take it to the next level? No problem! Additional hard facing, four position ripper shank, and other options are available.

SPECIFICATIONS

MACHINE SIZE	JAW CONFIG.	WEIGHT [LBS.]	THROAT DEPTH ["]	MOVING JAW WIDTH ["]	FIXED JAW WIDTH ["]	MAX. OPENING ["]
40 - 52K 20 - 25T	3/4	2760	21	20	28	31
	4/5	3220		20	28	
52 - 70K 25 - 35T	3/4	3475	24	23	32	35
	4/5	3775		23.5	32	
70 - 90K 35 - 45T	3/4	4595	27	24.5	35	40
	4/5	4780		25	34.5	
90 - 110K 45 - 55T	3/4	6570	31	28	39.5	46
	4/5	6950		28.5	39.5	
110 - 160K 55 - 80T	4/5	10,670	34	29	42.5	49

Specifications subject to change without notice.

CONCRETE PULVERIZER FEATURES

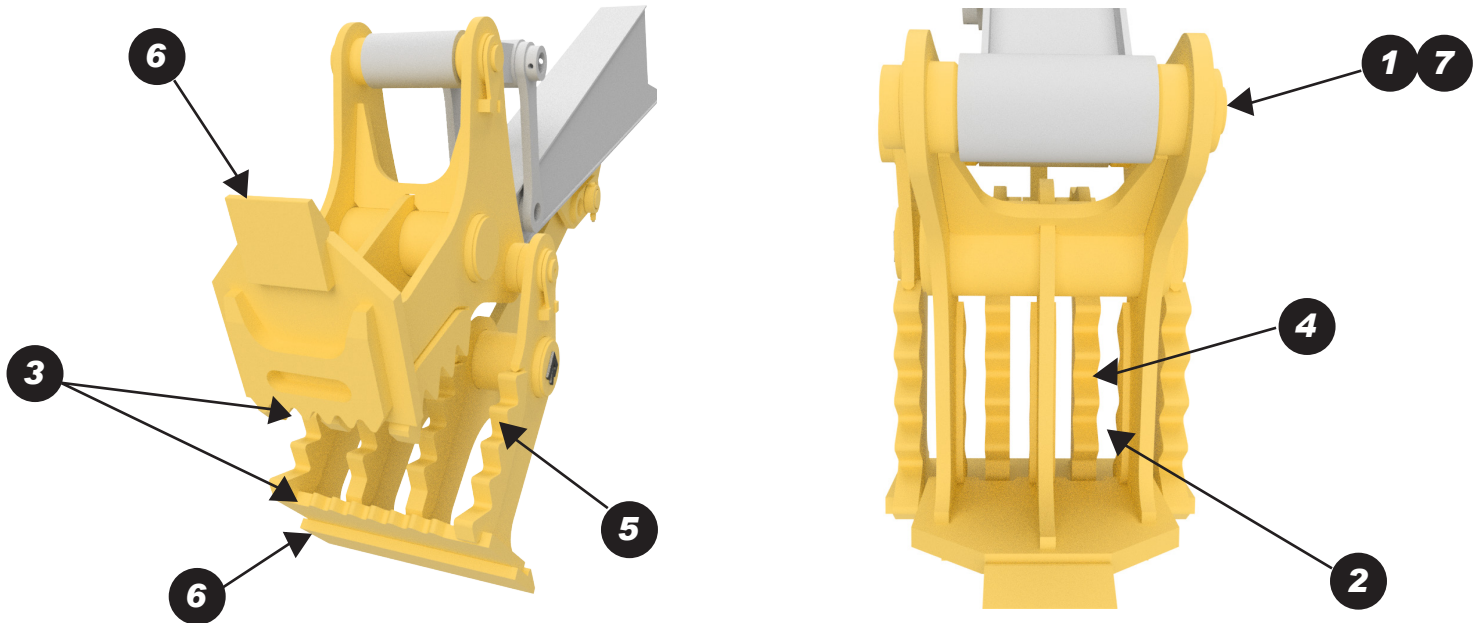

- 1 Simple and easy installation. Pins on in place of normal bucket, strut bracket welds to underside of the stick. No extra hoses or valves required!
- 2 Open jaw design promotes material flow-through and prevents material impaction.
- 3 Serrated pinch plates pull and sort rebar and other recyclable materials from reinforced concrete.
- 4 Choose from two different jaw configurations. 3 over 4 jaw for greater crushing force on thicker materials, or 4 over 5 jaw for finer material output.
- 5 Equipped with weld-in, high strength, abrasion resistant AR400 replaceable teeth, and pins and bushings for years of dependable service.
- 6 Equipped with weld-on, half-arrow cutting edges on nose and heel plates for scraping, lifting, and flipping concrete slabs, walls, bridge decks, and asphalt.
- 7 Available as pin-on or coupler (35T+ machines) configurations.

WARRANTY

Rockland Concrete Pulverizers are guaranteed against failure due to defective design, materials or workmanship for a period of two years or 4000 hours.



Distributed by:

ROCKLAND MANUFACTURING CO.

P.O. BOX 5
800-458-3773

BEDFORD, PA 15522
www.rocklandmfg.com